



KammBar Fleet – The most durable and aerodynamic steel roof bar system on the market.

Welcome to the Kamm Generation – the best in commercial vehicle roof storage accessories. KammBar Fleet is the leading steel roof bar system on the market, featuring our most aerodynamic bar profile ever.

The successor to Rhino’s incredibly popular Delta Bar system, KammBar Fleet offers the best in durability, great aesthetics, and quick and easy installation. The KammBar system is also available in aluminium and supplied with two load stop as standard, see our KammBar Pro range to learn more.

#KammGeneration



15 mins
Fitting time

DIMENSIONS

- Length	(L1)	1240mm - 1420mm - 1600mm - 1700mm
- Leg width	(W1)	133mm
- Cross tube width	(W2)	60mm
- Leg height - to top of the bar	(H1)	109mm
- Leg height - to bottom of the bar	(H2)	71.5mm

WEIGHT

Bar length	Bar	Combined weight of two legs	Total weight
- 1240mm	1.80 kg	0.76 kg	2.56 kg
- 1420mm	2.06 kg	0.76 kg	2.82 kg
- 1600mm	2.32 kg	0.76 kg	3.08 kg
- 1700mm	2.47 kg	0.76 kg	3.23 kg



PROTECTED AGAINST THE ELEMENTS



The robust high-tensile steel benefits from an inorganic topcoat zinc seal, which protects against the elements even in the harshest of weather conditions – providing 250 hours of salt spray protection (more than double that of the Delta Bar).

ALSO AVAILABLE IN ALUMINIUM



KammBar Pro pictured here

For premium performance and corrosion resistance, see our **KammBar Pro** (shown above) range, also supplied with two load stops as standard (not included in KammBar Fleet).

EXTREMELY AERODYNAMIC DESIGN



The unique shape of the bar profile is inspired by the work of Professor Wunibald Kamm - a pioneering aerodynamicist who established that a teardrop shape such as this is ideal for reducing drag.

MINIMAL WIND NOISE



The KammBar Fleet's aerodynamic shape almost entirely eliminates wind noise.

BESPOKE FITTING



KammBar Pro pictured here

Available in two, three and four bar configurations, the KammBar Fleet comes complete with a fitting kit that includes bespoke pads and spacers, tailored to the mounting points of every vehicle.

FAST FITTING WITH PREASSEMBLED LEGS



Supplied with the saddles loosely fastened into place within the legs, allowing for quick and easy fitment.

STYLISH LEG COWLS



The strong steel legs are covered by aesthetic composite covers to add to the modern, premium look of the product.

DURABLE AND BUILT TO LAST



KammBar Fleet has been rigorously tested by our inhouse team of design engineers to ensure it is strong and robust enough to withstand the challenges of day-to-day usage.

BEACON BRACKET



This bracket is a beacon support that securely holds single & triple bolt fixing beacons in place, increasing the functionality of the system. Sold separately.

LOCK UPGRADE KITS



KammBar Pro with locks pictured here

Lock kits can be purchased separately to provide additional theft deterrence and security.

SINGLE RETAIL BOX

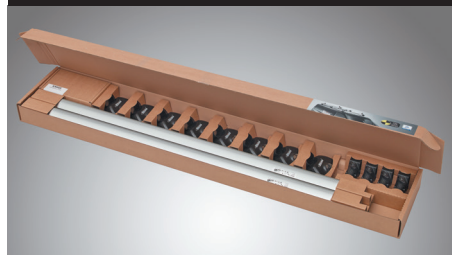

All KammBar Fleet systems are supplied in a single package. This ensures quick and efficient shipping, minimising any risk of delays as opposed to sending multiple packages.

MATERIAL	WHERE USED	ADVANTAGES
Alloy Steel		
- E320+CR2 S2	- Cross tubes	- High tensile, yield strength
Composite		
- LDPE - Polypropylene (PPCP)	- Crosstube end cap	
Mild steel		
- HR4, powder coat textured black	- Bar leg - Bar saddle	- High strength - Corrosion resistant
Fixings		
- Size M8 8.8 grade steel bolts, A2 stainless steel M8 nuts		
Tools required for installation 🔧		
- 10mm spanner, 13mm spanner, allen key (included)		

KammRoller™

To complement the KammBar range, we have also redesigned our rear roller system. The new KammRoller, compatible with both Fleet and Pro bars, is now more durable and easier-to-fit than ever before. KammRoller is lighter than its predecessor, with a reduction of up to 30% in weight.

Our design team have managed to reduce the product's weight without compromising on its strength. In fact, thanks to replacing the plastic roller inserts with steel versions, this roller is much more reliable than the old product. Its new aluminium construction fits in seamlessly with both KammBar Pro and KammBar Fleet, as well as with modern commercial vehicles.

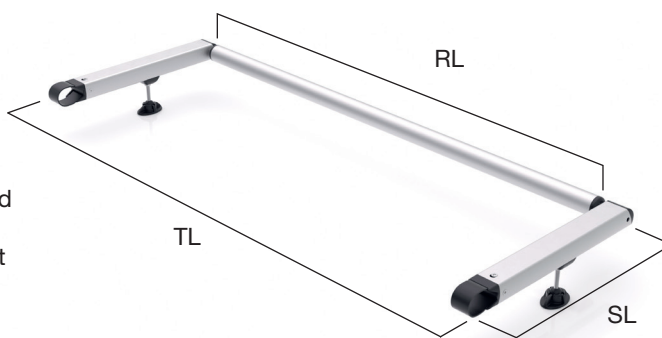

17 mins
Fitting time

FEATURES

- Roller now made from aluminium and considerably lighter
- New support pad fitting, enabling quicker and easier installation
- New steel roller inserts for a more durable design
- 50kg rated
- Rhino branded end caps
- Bespoke fitment for every vehicle



TECHNICAL

Roller length (RL)	Total length (TL)	Support arm length (SL)	Weight
656mm – 816mm – 956mm – 1056mm – 1114mm	804mm – 964mm – 1104mm – 1204mm – 1262mm	225mm – 300mm – 350mm – 430mm – 490mm – 530mm	min 1.28kg / max 2.23kg

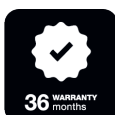

36 WARRANTY months